

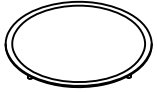

# RENDER

|   |   |   |
|---|---|---|
| A |  | 1 |
| B |  | 1 |

**1** Ax1  
Bx2

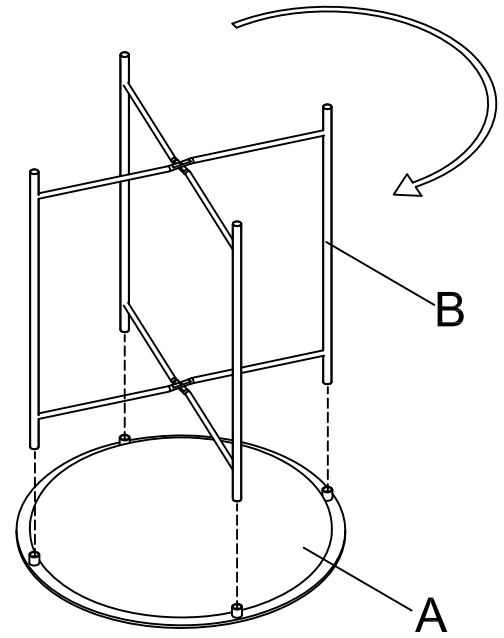
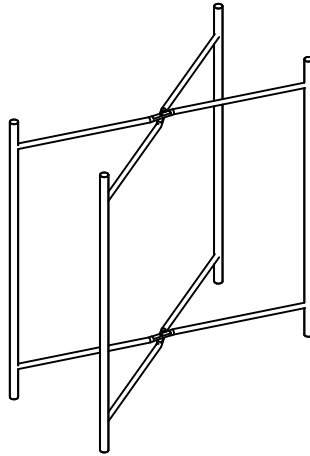

**2**

